

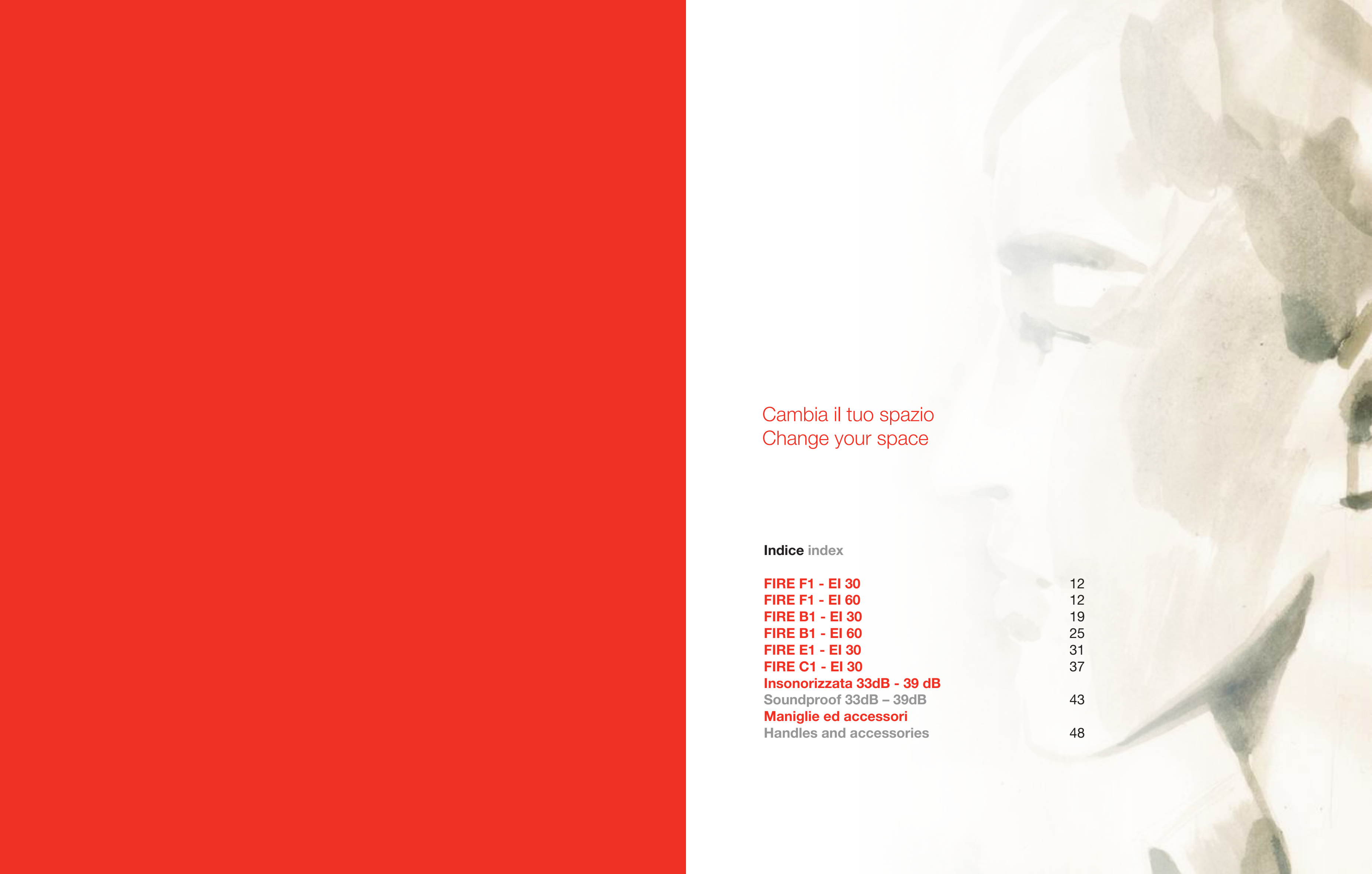

ITALIAN DOOR STORY

Design your hotel style

A watercolor illustration of a woman's face in profile, looking towards the left. Her hands are raised, holding a large, light-colored flower. The style is soft and artistic, with visible brushstrokes and a muted color palette of greens, yellows, and greys. The background is a solid, vibrant red on the left side, which transitions into the white background of the rest of the page.

Cambia il tuo spazio  
Change your space

**Indice index**

<b>FIRE F1 - EI 30</b>	12
<b>FIRE F1 - EI 60</b>	12
<b>FIRE B1 - EI 30</b>	19
<b>FIRE B1 - EI 60</b>	25
<b>FIRE E1 - EI 30</b>	31
<b>FIRE C1 - EI 30</b>	37
<b>Insonorizzata 33dB - 39 dB</b>	
<b>Soundproof 33dB - 39dB</b>	43
<b>Maniglie ed accessori</b>	
<b>Handles and accessories</b>	48



## Un'organizzazione fondata su razionalità del sistema, esperienza, innovazione

GD DORIGO è il risultato di quarant'anni di investimenti continui, finalizzati al miglioramento dell'ambiente produttivo con una particolare cura delle strutture che ospitano le linee di trasformazione della materia e di realizzazione delle porte finite.

### **An organisation founded on a rational system, experience and innovation.**

GD DORIGO today is the result of forty years of on-going investments aimed at improving its manufacturing environment, paying special attention to the structures which house the lines for processing and manufacturing the finished product.



## Il cuore dell'impresa

GD DORIGO rappresenta una delle principali realtà industriali italiane che ha saputo evolvere l'eccellente maestria artigiana in processi d'industrializzazione avanzati, nell'ambito della produzione di porte d'arredo per interni.

### **The heart of the company.**

GD DORIGO is one of the main Italian manufacturing companies able to manage craftsman expertise and develop it into advanced engineering processes, specifically focused on the design and manufacture of interior doors.



## Il lab del Made in Italy aziendale dove prendono forma le nuove idee

Il Design in GD DORIGO è da sempre una delle principali leve strategiche su cui l'azienda ha poggato la propria capacità di distinguersi nel mondo dei produttori di porte per interni. Tutto nasce in un "laboratorio del made in Italy" che dà forma alle nuove idee e stimola sperimentazioni costruttive trasformandole in porte di successo.

### **GD DORIGO, a lab where new ideas are shaped.**

Design has always been a strategic asset for GD DORIGO, one which distinguishes the company from other manufacturers of interior doors. It all began in a real laboratory for the 'Made in Italy' label, where new ideas take shape and construction experiments are carried out.



## L'impegno per la qualità e la sicurezza sviluppato incessantemente giorno per giorno è la base della filosofia produttiva di GD DORIGO

Un istituto autorizzato, operante secondo le normative internazionali ha riconosciuto che GD DORIGO lavora in un sistema aziendale certificato secondo le normative UNI EN ISO 9001: 2015. La certificazione conferma ufficialmente il giudizio degli acquirenti, che da sempre apprezzano i prodotti e i servizi dell'azienda.

### **Total everyday commitment to quality and safety is the industrial philosophy of GD DORIGO.**

An internationally recognised authorised institute has acknowledged that GD DORIGO operates according to UNI EN ISO 9001: 2015 standards. Certification officially confirms the judgement of our customers, who have always appreciated the company's products and services.







# design your hotel style

**Porte EI tagliafuoco, insonorizzate nel rispetto della normativa.  
Impegno costante per la qualità e la sicurezza**

Se nelle abitazioni private la porta EI tagliafuoco rappresenta una scelta di serenità in più per la famiglia, negli ambienti pubblici, quali hotel, residence, uffici, ospedali, scuole e comunità, la sicurezza è d'obbligo ed è regolamentata dal Decreto Ministeriale 09.04.94.

Le porte EI tagliafuoco sono la prova concreta della sensibilità e dell'attenzione di GD Dorigo verso la normativa in quanto sono tutte dotate di certificazione e conformi alla norma UNI-EN 1634-1.

EI 30 e EI 60 rappresentano i tempi espressi in minuti di resistenza al fuoco ottenuti dalle porte GD Dorigo durante i test di laboratorio, minuti preziosi che in caso di emergenza possono salvare molte vite umane.

**Con le porte EI tagliafuoco GD Dorigo abitare bene è soprattutto abitare sicuri.**

**Fireproof door and soundproof, exceeds all safety codes.  
Effort into quality and security**

If in private homes the EI fireproof door represents an extra choice of serenity for the family, in public environments, such as hotels, residences, offices, hospitals, schools and communities, safety is a must and is regulated by Ministerial Decree 09.04. 94.

The EI fire doors are the concrete proof of GD Dorigo's sensitivity and attention to the legislation as they are all certified and compliant with the UNI-EN 1634-1 standards.

EI 30 and EI 60 represent the times expressed in minutes of fire resistance obtained from GD Dorigo doors during laboratory tests, precious minutes that in case of emergency can save many human lives.

**With the EI fireproof doors by GD Dorigo, living well means living safe.**



art collection  
Art. 113A  
Laccato bianco  
cassa - door frame R40



## Hotel doors collection

# Una collezione eclettica,

versatile che si presta ad un uso che va oltre a quello abitativo e professionale. Le porte della collezione Hotel, declinabili nelle più varie cromie, ben si prestano per gli ambienti alberghieri e ricettivi, in cui il binomio estetica e funzionalità costituisce spesso l'ago della bilancia nelle scelte di arredo dei progettisti. GD DORIGO, con le porte Hotel, risponde a queste sollecitazioni con gusto, armonia, flessibilità.

This eclectic, versatile collection that lends itself to be used beyond the residential and professional standard applications. The doors of the Hotel collection by GD DORIGO available with the most varied colors are perfect for hotels and hospitality environments where the combination of "aesthetics" and "functionality" often constitutes to the balance in the choice of furniture by designers. GD DORIGO is the perfect answer to these needs while offering taste, harmony and flexibility.





**imago collection**  
Art. 13 con incisione laser personalizzata  
Art. 13 with personalized laser engraving  
**Rovere miele**  
cassa - door frame R40  
portale - portal P970



**Hotel doors collection**

## Porte personalizzate

Il nostro lavoro parte dall'analisi delle richieste funzionali ed estetiche del cliente, allo scopo di individuare la soluzione perfetta per le sue esigenze. I nostri tecnici sono in grado di fornire consulenze personalizzate e, grazie agli oltre 40 anni di esperienza, è possibile realizzare modelli esclusivi sia per quanto riguarda le finiture, le misure ed i sistemi di chiusura garantendo prodotti certificati e di alta qualità.

### Tailor made doors

Our work starts from the analysis of the customer's functional and aesthetic requests, in order to identify the perfect solution for his needs. Our technicians are able to provide personalized consultancy and, thanks to over 40 years of experience, it is possible to create exclusive models as regards the finishes, the dimensions and the locks solutions, guaranteeing certified and high quality products.





venus collection  
Art. 448  
Laccato bianco  
cassa - door frame R80

## Hotel doors collection

**FIRE F1 - EI 30**  
**FIRE F1 - EI 60**



Resistenza al fuoco  
30 minuti  
Fire resistance  
30 minutes

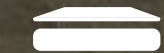

Versione Plantext  
Plantext version

◀ **Pegaso  
Medusa**



Resistenza al fuoco  
60 minuti  
Fire resistance  
60 minutes



Versione laccata  
Lacquered version

◀ **Venus  
Art  
Materia**



Fono isolamento  
29dB - 39dB  
Sound insulation  
29dB - 39dB



Versione legno  
impiallacciato  
Veneered wood  
version

◀ **Imago**



Prova fumi  
Smoke test



**venus collection**  
Art. 448  
Laccato bianco  
cassa - door frame R80

## Hotel doors collection

- Porta resistente al fuoco con cerniere a scomparsa complanare lato a tirare
- Classificazione EI 30 o EI 60 insonorizzate 29dB con chiudiporta a scomparsa o 39 dB con chiudiporta a vista
- Pannello spessore mm. 60
- Cassa spessore mm. 50 con installazione su pareti in muratura o cartongesso da spessore mm. 100 minimo
- Coprifilo telescopico ambo i lati
- Guarnizione acustica fumi freddi
- Guarnizione intumescente
- Fire resistant door with concealed hinges flush in the pull side
- Classification EI 30 or EI 60 soundproofed 29dB with concealed door closer or 39 dB with visible door closer
- Panel thickness mm. 60
- Door frame 50 mm thick with installation on masonry or plasterboard walls from thickness mm. 100 minimum
- Telescopic finishing lists on both sides
- Acoustic cold smokes seal
- Intumescent seal



**laccati opachi**  
matt lacquered

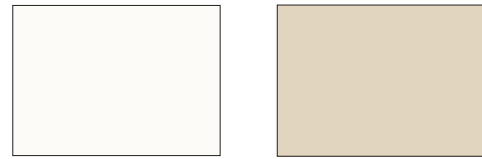

Bianco GD 08

RAL 1013 8A



RAL 9001 8J

RAL 9010 8K

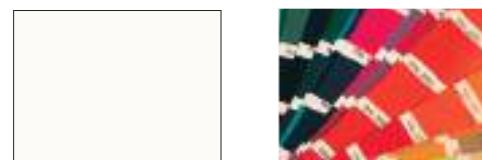

RAL 9016 8O

Altri colori RAL



venus collection Art. 376

**F1 - EI 30**  
**F1 - EI 60**  
**Insonorizzato 29 dB Soundproof 29 dB**  
**Cassa S30 Door frame S30**

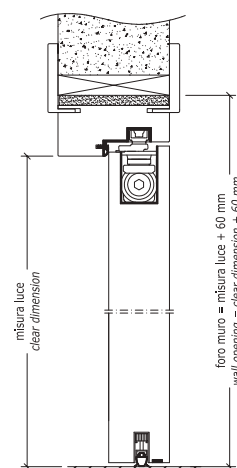
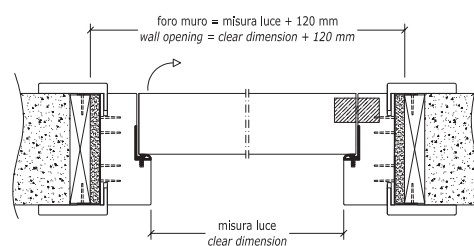

**F1 - EI 30**  
**F1 - EI 60**  
**Insonorizzato 39 dB Soundproof 39 dB**  
**Cassa S30 Door frame S30**

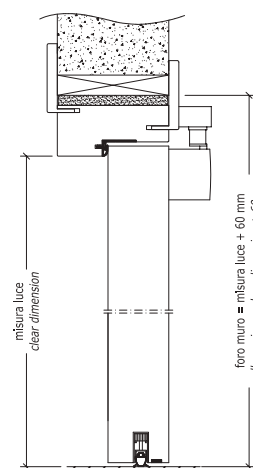
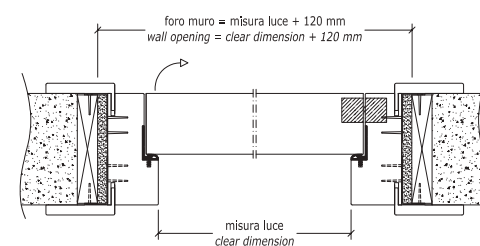

**alcuni degli accessori disponibili**  
some of the available accessories



**Chiudiporta a scomparsa**  
Concealed door closer



**Chiudiporta aereo con braccio a slitta**  
Slide arm overhead door closer



**Cerniere a scomparsa**  
Concealed Hinges



**Rostri di tenuta**  
Safety bolts



**Serratura elettronica per hotel**  
**a movimento magnetico Opera Bit**  
Electronic lock for hotels  
with magnetic movement Opera Bit



**Parafreddo**  
Coldfender



**imago collection**  
Art. 370T  
Rovere ghiaccio  
cassa - door frame R40

206



## Hotel doors collection

# FIRE B1 - EI 30



Resistenza al fuoco  
30 minuti  
Fire resistance  
30 minutes



Versione Plantext  
Plantext version



Versione laccata  
Lacquered  
version



Versione legno  
impiallacciato  
Veneered wood  
version



Fono isolamento  
31dB - 39dB  
Sound insulation  
31dB - 39dB

**Pegaso  
Medusa**

**Venus  
Art  
Materia**

**Imago**



Prova fumi  
Smoke test





**imago collection**

Art. 370T

Rovere ghiaccio

cassa - door frame R40



**Hotel doors collection**

- Porta resistente al fuoco con cerniere a vista
- Classificazione EI 30 insonorizzate 31dB o 39dB con chiudiporta a vista
- Pannello spessore mm. 52
- Cassa spessore mm. 50 con installazione su pareti in muratura o cartongesso da spessore mm. 100 minimo
- Coprifilo telescopico ambo i lati
- Guarnizione acustica fumi freddi
- Guarnizione intumescente
  
- Fire resistant door with visible hinges
- Classification EI 30 soundproofed 31dB or 39 dB with visible door closer
- Panel thickness mm. 52
- Door frame mm. 50 thick with installation on masonry or plasterboard walls from thickness mm. 100 minimum
- Telescopic finishing lists on both sides
- Acoustic cold smokes seal
- Intumescent seal



essenze legno  
wood veneers



Rovere miele 07



Rovere ghiaccio R2



Rovere tabacco R3



Rovere moka R1



Noce canaletto 03



imago collection Art.891

**B1 - EI 30**  
**Insonorizzato 31 dB - 39 dB**  
**Soundproof 31 dB - 39 dB**  
**Cassa C30 Door frame C30**

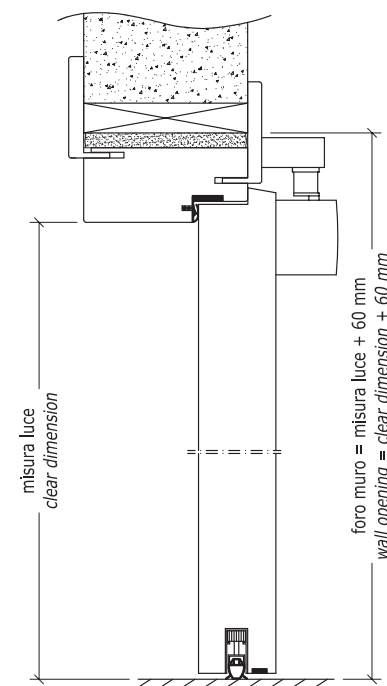
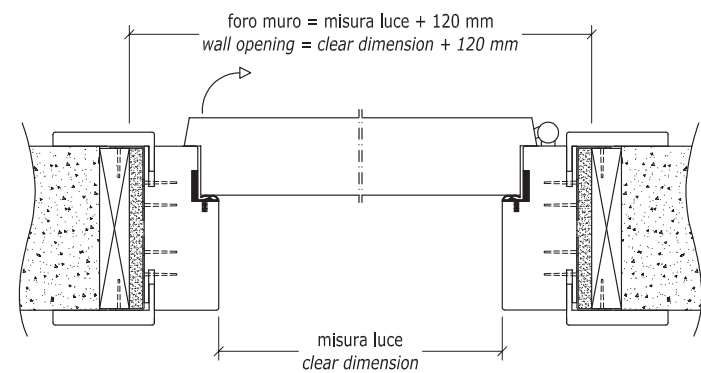

alcuni degli accessori disponibili  
some of the available accessories



**Chiudiporta aereo con braccio a slitta**  
**Slide arm overhead door closer**



**Cerniere a 3 gambi a vista**  
**3 pins visible hinges**



**Serratura di sicurezza**  
**Security lock**



**Cilindro chiave/pomolo MK**  
**MK cylinder key/knob**



**Rostrì di tenuta**  
**Safety bolts**



**Parafreddo**  
**Coldfender**



408



**imago collection**

Art. 881  
Rovere ghiaccio  
cassa - door frame R40

**Hotel doors collection**

**FIRE B1 - EI 60**



Resistenza al fuoco  
60 minuti  
Fire resistance  
60 minutes



Fono isolamento  
31 dB  
Sound insulation  
31 dB



Prova fumi  
Smoke test

Versione Plantext  
Plantext version

▲  
**Pegaso  
Medusa**

Versione laccata  
Lacquered  
version

▲  
**Venus  
Art  
Materia**

Versione legno  
impiallacciato  
Veneered wood  
version

▲  
**Imago**





**imago collection**

Art. 88I

Rovere ghiaccio

cassa - door frame R40



**Hotel doors collection**

- Porta resistente al fuoco con cerniere a vista
- Classificazione EI 60 insonorizzate 31dB con chiudiporta a vista
- Pannello spessore mm. 70
- Cassa spessore mm. 50 con installazione su pareti in muratura o cartongesso da spessore mm. 100 minimo
- Coprifilo telescopico ambo i lati
- Guarnizione acustica fumi freddi
- Guarnizione intumescente
  
- Fire resistant door with visible hinges
- Classification EI 60 soundproofed 31dB with visible door closer
- Panel thickness mm. 70
- Door frame mm. 50 thick with installation on masonry or plasterboard walls from thickness mm. 100 minimum
- Telescopic finishing lists on both sides
- Acoustic cold smokes seal
- Intumescent seal





essenze legno  
wood veneers



Frassino bianco F5



Frassino bianco FE



Frassino decapè bianco D1



Frassino decapè tortora D3



Frassino decapè cenere D4



Frassino decapè antracite D5



imago collection Art.13

B1 - EI 60  
Insonorizzato 31 dB  
Soundproof 31 dB  
Cassa C30 Door frame C30

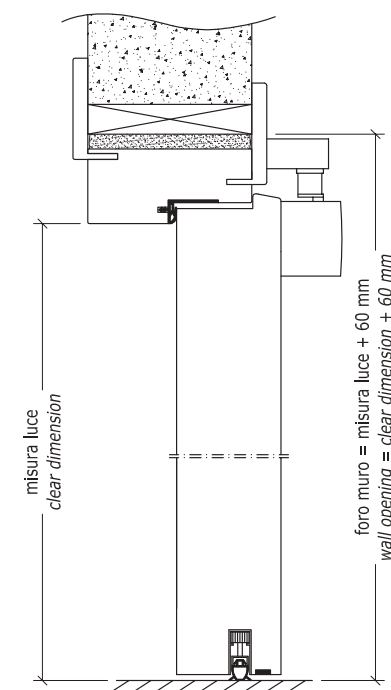
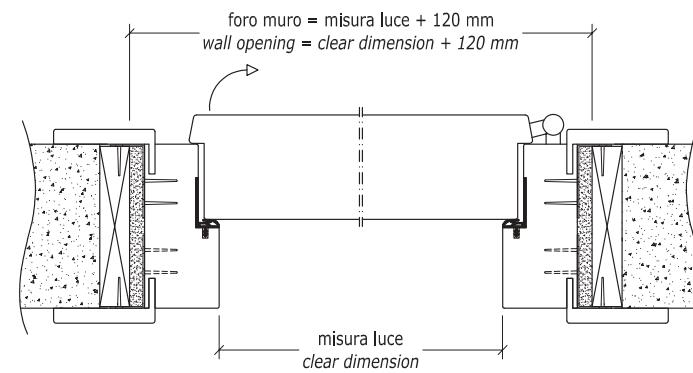

alcuni degli accessori disponibili  
some of the available accessories



Chiudiporta aereo con braccio a slitta  
Slide arm overhead door closer



Cerniere a 3 gambi a vista  
3 pins visible hinges



Serratura di sicurezza antipanico  
con incontro elettrico  
Panic exit lock with electric strike plate



Cilindro chiave/pomolo GMK  
con segnalatore di presenza  
GMK Cylinder key/knob  
with occupancy indicator



Rostrì di tenuta  
Safety bolts

Parafreddo  
Coldfender





**eterea collection**  
Art. 11E  
laccato - lacquered  
cassa - door frame **ES30**

## Hotel doors collection

# FIRE E1 - EI 30

503

502-510



Resistenza al fuoco  
30 minuti  
Fire resistance  
30 minutes



Versione Plantext  
Plantext version



Versione laccata  
Lacquered  
version



Versione legno  
impiallacciato  
Veneered wood  
version



Metalli  
Metals



Prova fumi  
Smoke test

**Pegaso  
Medusa**

**Venus  
Art  
Materia**

**Imago**

**Eterea**



**eterea** collection  
Art. 11E  
grafite - cassa - door frame ES30

## Hotel doors collection

- Porta rasomuro resistente al fuoco
- Versione a spingere o a tirare
- Classificazione EI 30 con cerniere autochiudenti
- Pannello spessore mm. 53
- Cassa con installazione su pareti in muratura o cartongesso
- Guarnizione acustica
- Guarnizione intumescente
- Fire resistant flush-to-the-wall door
- Push or pull version
- Classification EI 30 with self closing hinges
- Panel thickness mm. 53
- Door with installation on masonry or plasterboard walls
- Acoustic cold smokes seal
- Intumescent seal



## materia



Graffite M4

## metalli - metals



Starline A253 H4

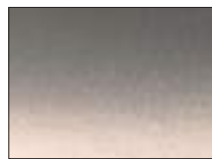

Starline A256 H5

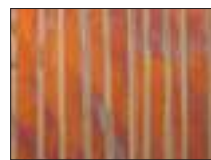

Aramen CA08 H1



Aramen CA09 H2



eterea collection art. 900M

## E1 - EI 30 Cassa ES30 Door frame ES30

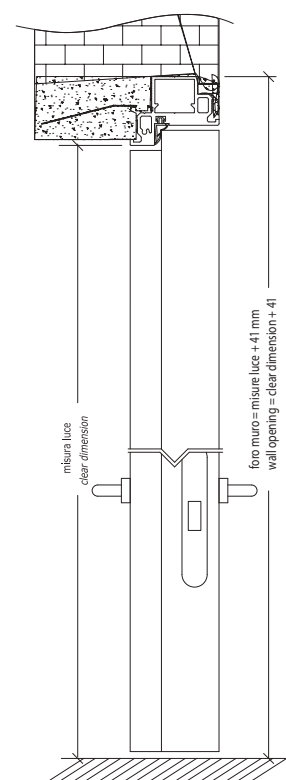
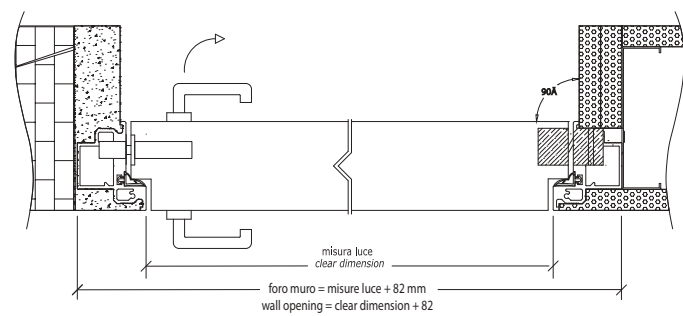

## alcuni degli accessori disponibili some of the available accessories

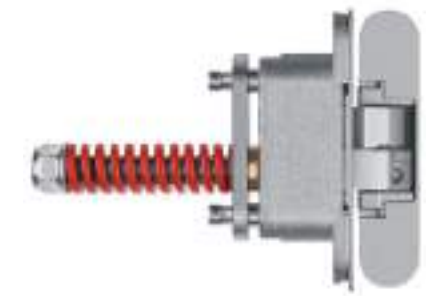

### Cerniere a scomparsa autochiudenti Self closing concealed hinges



### Serratura di sicurezza antipanico Opera XT Antipanic magnetic lock Opera XT



### Cilindro chiave/pomolo GMK con segnalatore di presenza GMK Cylinder key/knob with occupancy indicator



### Spioncino Spy-hole



### Rostrì di tenuta Safety bolts



### Parafreddo Coldfender



pegaso collection  
Art. P13  
quarzo  
cassa - door frame R40

312

## Hotel doors collection

# FIRE C1 - EI 30



Resistenza al fuoco  
30 minuti  
Fire resistance  
30 minutes

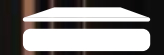

Versione Plantext  
Plantext version

▲  
**Pegaso**

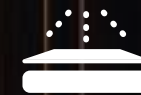

Versione laccata  
Lacquered version

▲  
**Venus**  
Articoli lisci  
plain articles

**Art  
Materia**



Versione legno  
impiallacciato  
Veneered wood  
version

▲  
**Imago**  
Articoli lisci  
plain articles



**pegaso** collection  
Art. P13  
quarzo  
cassa - door frame R40



## Hotel doors collection

- Porta resistente al fuoco con cerniere a bandella a vista
- Classificazione EI 30 con chiudiporta a vista
- Pannello spessore mm. 45
- Cassa spessore mm.40 con installazione su pareti in muratura o cartongesso da spessore mm. 100 minimo
- Coprifilo telescopico ambo i lati
- Guarnizione acustica fumi freddi
- Guarnizione intumescente
- Fire resistant door with visible butterfly hinges
- Classification EI 30 with visible door closer
- Panel thickness mm.45
- Door frame mm. 40 thick with installation on masonry or plasterboard walls from thickness mm. 100 minimum
- Telescopic finishing lists on both sides
- Acoustic cold smokes seal
- Intumescent seal



finiture plantext  
plantext finishes

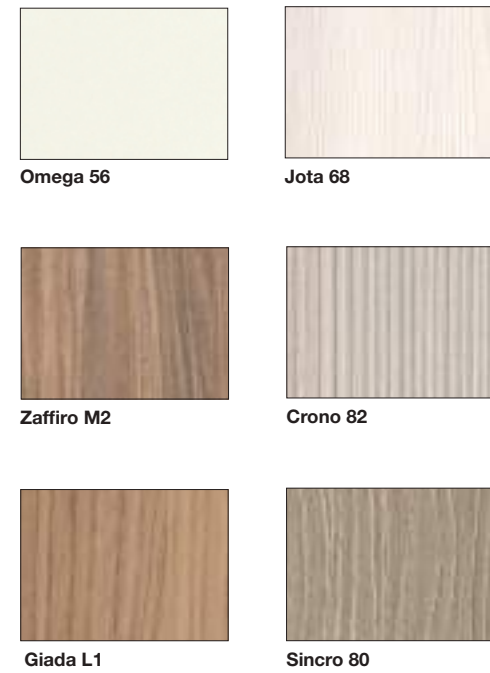

pegaso collection Art. P11

C1 - EI 30  
Cassa S30 Door frame S30

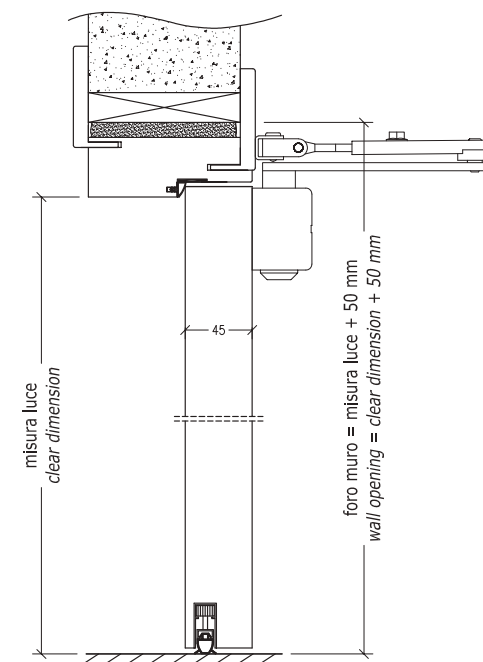
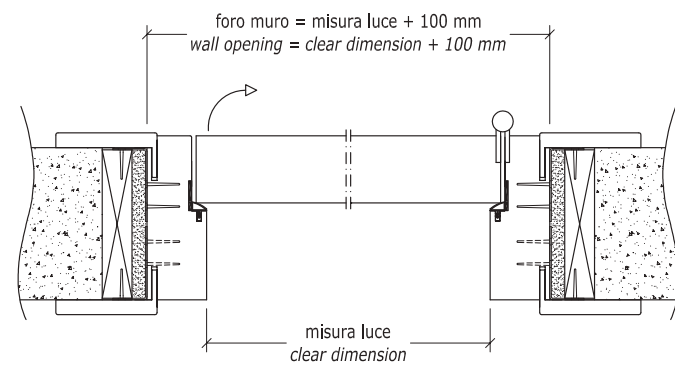

alcuni degli accessori disponibili  
some of the available accessories



Chiudiporta con braccio a compasso  
Standard arm door closer



Cerniere a bandella a vista  
Visible butterfly hinges



Serratura di sicurezza antipanico  
con incontro elettrico  
Panic exit lock with electric strike plate



Cilindro MK chiave/pomolo  
MK Cylinder key/knob



Rostri di tenuta  
Safety bolts



Parafreddo  
Coldfender



medusa collection  
Art. M730  
giada  
cassa - door frame R40

## Hotel doors collection

# INSONORIZZATE 33dB e 39dB

  
Fono isolamento  
33dB - 39dB  
Sound insulation  
33dB - 39dB

  
Versione Plantext  
Plantext version

▲  
**Pegaso  
Medusa**

  
Versione laccata  
Lacquered  
version

▲  
**Venus  
Art  
Materia**

  
Versione legno  
impiallacciato  
Veneered wood  
version

▲  
**Imago**



**medusa** collection  
Art. M730  
giada  
cassa - door frame R40



## Hotel doors collection

- Porta insonorizzata 33dB o 39dB con cerniere a vista
- Pannello spessore mm. 52
- Cassa spessore mm. 50 con installazione su pareti in muratura o cartongesso da spessore minimo mm. 100
- Coprifilo telescopico ambo i lati
- Guarnizione acustica
- Soundproof door 33dB o 39dB with visible hinges
- Panel thickness mm. 52
- Door with installation on masonry or plasterboard walls from thickness mm. 100 minimum
- Telescopic finishing lists on both sides
- Acoustic seal





finiture plantext  
plantext finishes



Rubino L3



Onice L2



Quarzo L4



Ambra L0



Zeta 57



Gamma 52



Platino M1



Agata L5

Insonorizzato 33dB - 39dB  
Soundproof 33 dB - 39dB  
Cassa C30 Doorframe C30

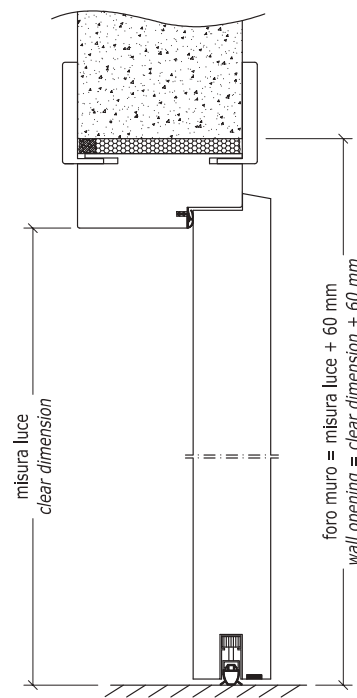
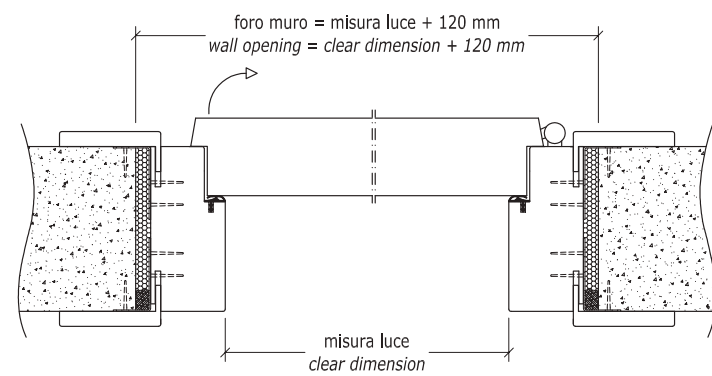

medusa collection art. M112

alcuni degli accessori disponibili  
some of the available accessories



Cerniere a 3 gambi a vista  
3 pins visible hinges



Serratura di sicurezza con catenaccio  
Security lock with door bolt



Cilindro chiave/chiave  
Cylinder key/key



Parafreddo  
Coldfender



maniglie e accessori  
handles and accessories



Set pomolo - maniglia Stoccolma  
Stoccolma handle - knob set



Set pomolo - maniglia Austria  
Austria handle - knob set



Set pomolo - maniglia Olanda  
Olanda handle - knob set



Set pomolo - maniglia Ucraina  
Ucraina handle - knob set



Maniglioni: Florida - Arizona - Texas  
Pull handles: Florida - Arizona - Texas



Fermaporta 3690 - 3691  
Doorstop 3690 - 3691



Numeri camera - pittogrammi  
Room numbers - pictograms





ITALIAN DOOR STORY

**GD DORIGO SPA**

Via Giovanni Pascoli, 23  
31053 Pieve di Soligo TREVISO - Italy  
T. +39 0438 840153 / F. +39 0438 82268  
[www.gd-dorigo.com](http://www.gd-dorigo.com) / [info@gd-dorigo.com](mailto:info@gd-dorigo.com)

Art direction: Ikebeo Graphic Link - Treviso  
Pictures concept / Photography / 3D design: Accent Studio Barbiero - Padova  
All right reserved.  
Print: Industria Grafica Si.z  
Edition: 2020

**Note**

Le fotografie dei prodotti ed i campioni dati al cliente, hanno valore puramente indicativo e pubblicitario. Il cliente non potrà fondare alcun reclamo su eventuali differenze tra la merce fornita e quanto risulta dal materiale dimostrativo in suo possesso.  
La GD Dorigo Spa, si riserva inoltre la facoltà di apportare ai propri prodotti, le migliorie di carattere tecnico e costruttivo che riterrà opportune, in qualsiasi momento.

**Notes**

The photos of the products and the given samples to the customer have only indicative and advertising value. The customer can not found any claim on eventual differences between the supplied goods and the demonstrative samples in his/her possession.  
Moreover GD Dorigo Spa reserves the right to make technical, constructive or design changes at any time and without prior notice.





ITALIAN DOOR STORY

[gd-dorigo.com](http://gd-dorigo.com)